

USER MANUAL



IDEAL-P

**UNIVERSAL DIGITAL INDICATOR
FOR PROCESS AND TEMPERATURE
INPUT SIGNAL**

INDEX
GENERAL INFORMATION

Package contents	4
Recycling instructions	4
General safety considerations	4
Symbols identification	4
Maintenance	5
Warranty	5
Conformity declaration	6
Device description	7
Dimensions and mounting	7
Display and keyboard	8
Installing and connecting recommendations	8
Connections	9
Process input (V)	9
Process input (mA)	10
Pt100 sensor input	11
Thermocouple (J, K, T and N) input.....	11
Relays output	11
Analog output	11

INPUT CONFIGURATION

Configuration menu	12
Input configuration	12
Process	13
Temperature	13

DISPLAY CONFIGURATION

Display programming	14
Display scaling	14
Process input	15
Temperature input	15

SETPOINTS CONFIGURATION

Setpoints configuration	16
-------------------------------	----

ANALOG OUTPUT CONFIGURATION

Analog output configuration menu	17
--	----

AVAILABLE KEYBOARD FUNCTIONS

MAX/MIN and RESET functions.....	18
Direct access to setpoints value	18
Return to default configuration	19
Access to lock-out configuration menu	19
Lock-out the analog output setting	19

CONFIGURATION LOCK-OUT

Lock-out menu	20
---------------------	----

INDEX**RELAY OUTPUT**

Description	22
Description of the operating modes	22
Mode of actuation HI, LO and HI/LO	22
Timing	22
Asymmetric hysteresis	22

ANALOG OUTPUT

Description	23
Description of the operating modes	23
Setpoint generator	23

SPECIFICATIONS

Technical specifications	24
--------------------------------	----

GENERAL INFORMATION

This manual does not constitute a contract or a commitment on the part of Diseños y Tecnología, S.A. All information contained in this document is subject to change without prior notice.

MANUAL VALID FOR INSTRUMENTS WITH i2.00 SOFT VERSION OR HIGHER

Package contents

With the instrument it is also supplied:

- Quick installation guide.
- Mounting panel accessories (a sealing gasket and 2 fixing clips).
- Wiring accessories (plug-in terminal block connectors and 2 key tools for cable insertion).
- 4 adhesive labels set with engineering units.

Recycling instructions

This electronic instrument is covered by the **2012/19/EU** European Directive so, it is properly marked with the crossed-out wheeled bin symbol that makes reference to the selective collection for electrical and electronic equipment which indicates that at the end of its lifetime, the final user cannot dispose of it as unsorted municipal waste.



In order to protect the environment and in agreement with the European legislation regarding waste of electrical and electronic equipments from products put on the market after 13 August 2005, the user can give it back, without any cost, to the place where it was acquired to proceed to its controlled treatment and recycling.

General safety considerations

All instructions and guidelines for the installation and manipulation that are present in this manual must be considered to ensure personal safety and to prevent damage to either the instrument or any equipment connected to it.

Safety of any equipment incorporated to this instrument is responsibility of the system installer.

If this electronic indicator is used in a manner not specified by the manufacturer in this manual, the protection provided by the instrument may be impaired.

Symbols identification



WARNING: Potential risk of danger.

Read completely related instructions when this symbol appears in order to know the potential risk and to know how to avoid it.



WARNING: Risk of electric shock.



Instrument protected by double isolation or reinforced isolation.

Maintenance

To guarantee instrument accuracy, it is recommended to check its compliance according to the technical specifications listed in this manual, performing calibrations regularly in accordance to operation criteria in each application.

Instrument calibration and/or adjustment should be performed only by an accredited laboratory or directly by the manufacturer.

Instrument repairs should only be carried out by the manufacturer or by its authorized partners.

For frontal device cleaning, just wipe it with a damp cloth and neutral soap product. **DO NOT USE SOLVENTS!**

Warranty

All products are warranted against defective material and workmanship for a period of five years from acquisition date.



If a product appears to have a defect or fails during the normal use within warranty period, please contact the distributor from whom you purchased the product to be given proper instructions.

This warranty does not apply to defects resulting from action of the customer such as mishandling or improper interfacing.

The liability under this warranty shall extend only to the repair of the instrument; no responsibility is assumed by the manufacturer for any damage which may result from its use.

CE Conformity

To obtain the declaration of conformity corresponding to this model enter our website **www.ditel.es**, where this document, the technical manual and other information of interest can be downloaded freely.

Device description

The **IDEAL-P** model of the KOSMOS series is a universal digital indicator that allows the user to configure the meter according to the type of input used:

PROCESS (V, mA)

THERMOCOUPLE (J, K, T and N)

Pt100 SENSOR

The basic instrument is a set consisting of the base and display circuits also incorporating by default, an analog output and another one of 1 relay type SPDT 8A isolated with respect to the input signal and the general power supply. These output circuits have independent connectors with output on the back of the instrument.

This model for the control of industrial processes has 4 digits and a programmable decimal point to visualize the input variables, and is easily scalable in the desired engineering units, either directly by the keyboard or by the actual input level. It also supplies a 24V DC signal as a transducer excitation and a 4-20mA analog output.

The **IDEAL-P** model is an indicator with digits of 14mm of height and maximum display range **-9999** to **9999**. The sign LED is outside, being placed to the left of the most significant digit.

The instrument has a keyboard with three buttons with which it is possible to interact with the internal software to configure it and adapt it to the desired operating characteristics. The programming is done through independent menus that incorporate messages for easy identification of the steps to follow when setting the type of input, configuring the display and / or configuring the working mode of the two available outputs.

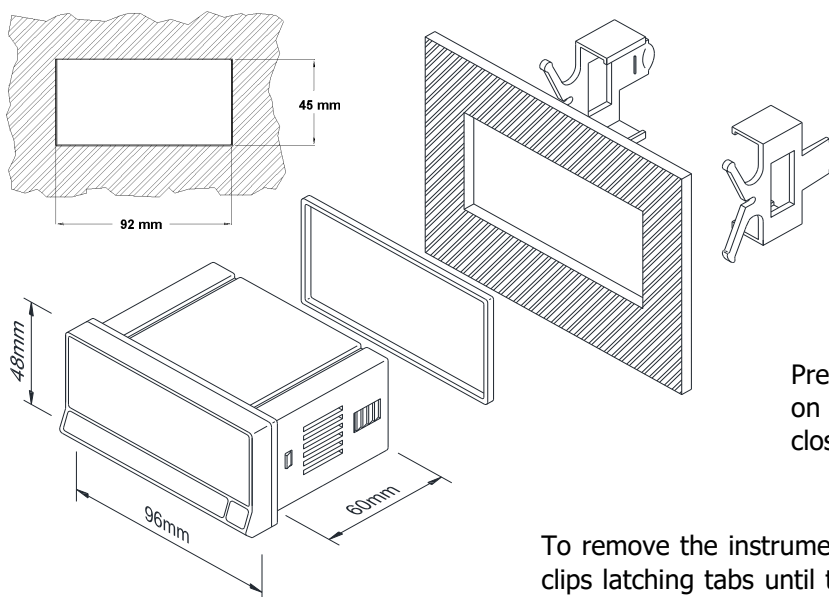
Dimensions and mounting

To install the instrument, prepare a 92x45mm panel cut-out and slide the unit inwards making sure of placing the sealing gasket between the front side panel and the frontal bezel.

While holding the unit in place, put the fixing clips on both sides of the case and slide them through the guide tracks until they reach the panel at the rear side.

Press slightly to fasten the clips to the latching slots on the case and get the unit fully assembled and close fitted to achieve a good sealing.

To remove the instrument from the panel, pull outwards the rear fixing clips latching tabs until they are disengaged, then slide fixing clips back over the case.

Display y teclado

There are two main function modes: **RUN** and **PRO**. **PRO** mode is when configuration menu is entered to programm the indicator, whereas **RUN** is the normal mode in which display shows the reading according to configuration and input signal value.

The table below summarizes display parts description and LEDs and keyboard function.

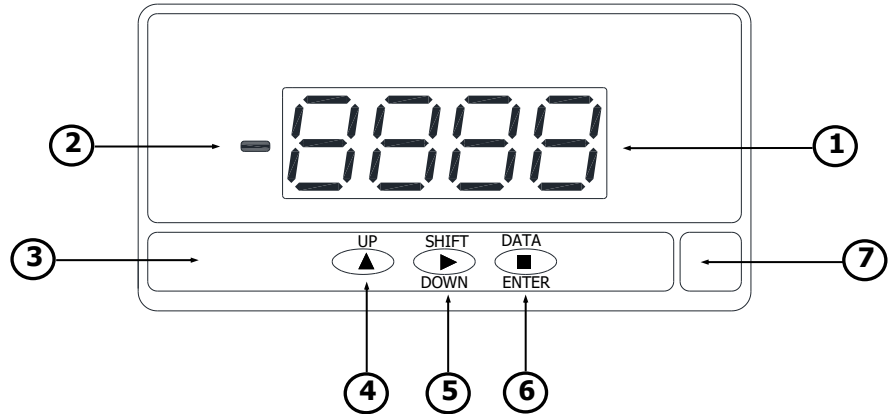

		RUN MODE	PRO MODE
1	4 white digit Display	Shows value according configuration. Display will flash when relay output is activated.	Shows steps and data during configuration.
2	Minus sign LED	It iluminates for negative readings.	It iluminates for negative values.
3	Keyboard	—	—
4	UP key	Increases the value of the setpoint generator if it is previously enabled in 'diMM' mode or increases the active digit if it is enabled in 'ProG' mode.	Shows Setpoints value. Increases value of active digit.
5	SHIFT / DOWN key	Displays the maximum and minimum values when the setpoint generator is not enabled. Update the maximum and / or minimum value stored to the current display value if you press more than 3s. Decreases the value of the setpoint generator if it is enabled in 'diMM' mode.	Shifts flashing active digit to the next right digit. Shows sequentially menu options.
6	DATA/ENTER key	Switch to PRO mode. Followed by pressing 'DOWN', enters to configure the value of the setpoint generator for the 'ProG' mode. Followed by pressing 'DOWN' for 5s, it allows to disable / enable the adjustment modes 'diMM' and 'ProG' of the setpoint generator.	Validates selected data and parameters. Moves one step forward in configuration menu. Changes to RUN mode.
7	Free space for units label	—	—

Installing and connecting recommendations

This instrument complies with the EU directives of EMC i LVD. Refer to the instructions in this manual to preserve safety protections.



WARNING: If this instrument is not installed and used in accordance with this instructions, the protection provided by it against hazards may be impaired.

To meet the requirements of EN 61010-1 standard, where the unit is permanently connected to main supply, its is obligatory to install a circuit breaking device easy reachable to the operator and clearly marked as the disconnecting device.

To guarantee electromagnetic compatibility, the following guidelines should be kept in mind:

- Power supply wires should be separatedly routed from signal wires and **never runned** in the same conduit.
- Use shielded cable for signal wiring.
- Cables section should be $\geq 0.25 \text{ mm}^2$.

Before connecting signal wires, signal type and input range should be verified to be within the right limits. **Do not connect simultaneously more than one input signal to the meter.**

Connections

The instrument has 4 rear connectors CN1 to CN4 in its unique format. The connectors layout is shown in the figure. All the aerial terminals supplied for the connection are of CAGE CLAMP® type technology.

Terminals for **CN2** connector admit cables with section from 0.2mm² up to 1.5mm² (AWG 24÷14).

Terminals for **CN1**, **CN3** and **CN4** connectors admit cables with section from 0.08mm² up to 2.5mm² (AWG 28÷12).

To perform wiring connections, strip the cable leaving from 7 to 10mm exposed to air, insert it in the proper terminal while pushing down the key insertion tool to open the clip inside the connector. Release the key tool to fix wire to the terminal.

Proceed in the same way for the rest of terminals. Once all connections are done, plug connectors to the instrument.

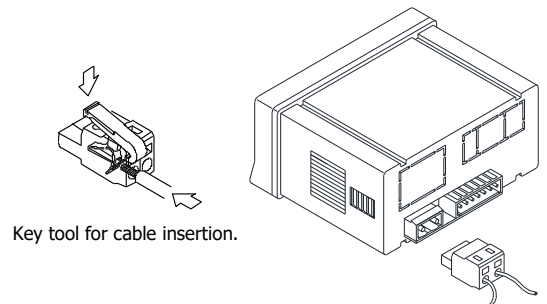
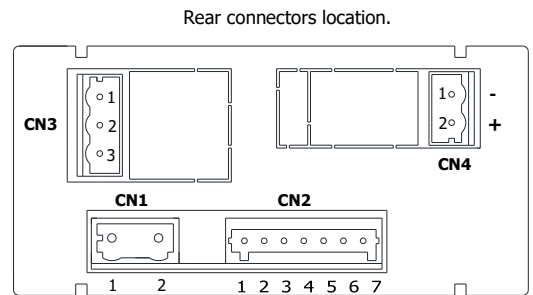

CN4 (analog output)	
1	- (mA)
2	+ (mA)

CN3 (relay)	
1	NO
2	CM
3	NC

CN1*	
1	Phase (AC)
2	Neutral (AC)

CN2 (Inputs, excitation)	
1	COMMON / Pt100 B / -TC
2	Pt100 A / +TC
3	N.C
4	Pt100 B
5	+mA
6	+EXC. 24V
7	+V

Notes:

NO: Normally open contact.

CM: Common contact.

NC: Normally closed contact.

* Polarity in CN1 is indistinct for DC power.



WARNING Isolation:

1500Vrms for 1 minute to signal terminals (CN2) and power terminals (CN1).

2500Vrms for 1 minute to signal terminals (CN2) and relay terminals (CN3).

2500Vrms for 1 minute to power terminals (CN1) and relay terminals (CN3).

1500Vrms for 1 minute to analog output terminals (CN4) and power terminals (CN1).

500Vrms for 1 minute to analog output terminals (CN4) and signal terminals (CN2).

Process input signal wiring diagrams (V)

4 WIRES CONNECTION WITH EXTERNAL EXCITATION

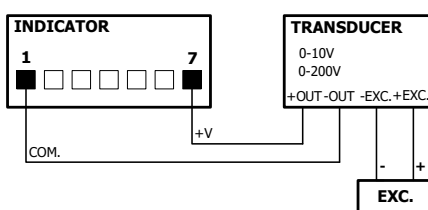

4 WIRES CONNECTION WITH EXCITATION SUPPLIED BY THE INDICATOR

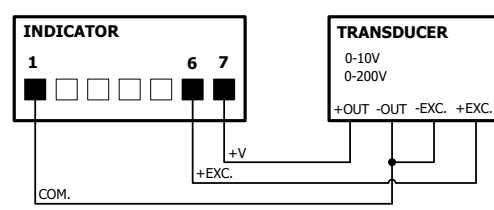

3 WIRES CONNECTION WITH EXTERNAL EXCITATION

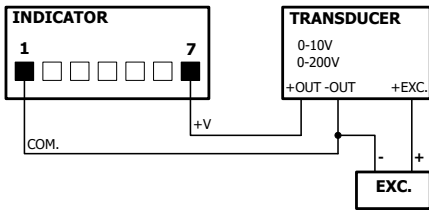

3 WIRES CONNECTION WITH EXCITATION SUPPLIED BY THE INDICATOR

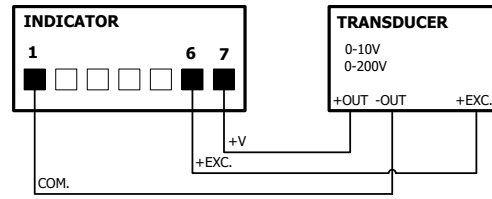

Process input signal wiring diagrams (mA)

4 WIRES CONNECTION WITH EXTERNAL EXCITATION

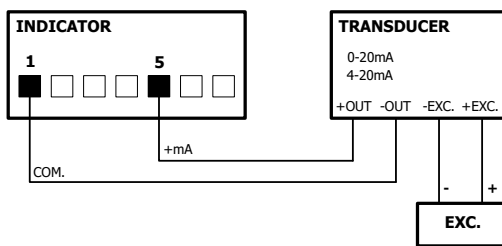

4 WIRES CONNECTION WITH EXCITATION SUPPLIED BY THE INDICATOR

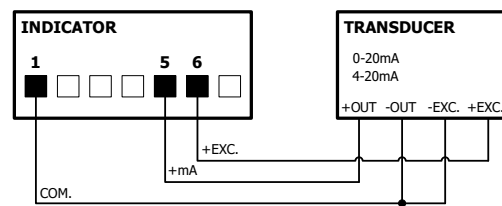

3 WIRES CONNECTION WITH EXTERNAL EXCITATION

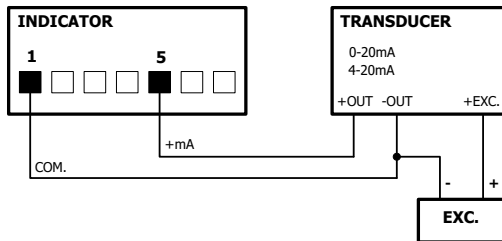

3 WIRES CONNECTION WITH EXCITATION SUPPLIED BY THE INDICATOR

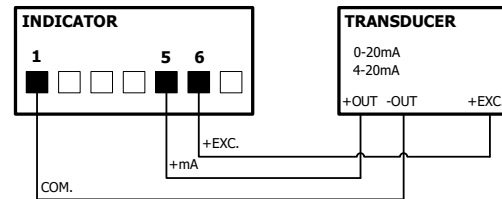

2 WIRES CONNECTION WITH EXTERNAL EXCITATION

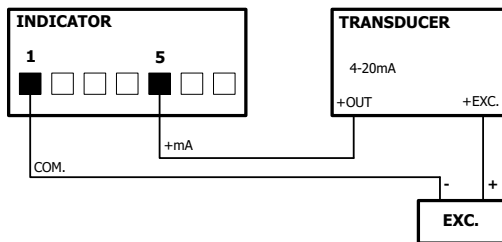

2 WIRES CONNECTION WITH EXCITATION SUPPLIED BY THE INDICATOR

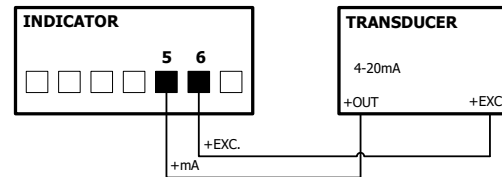

Connection for Pt100 probe (°C and °F)

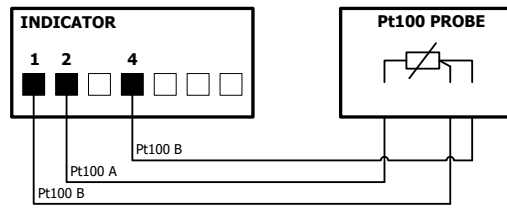

Connection for thermocouple input J, K, T and N (°C and °F)

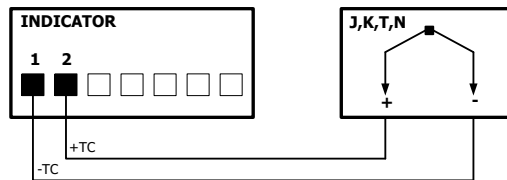

Relay output connection

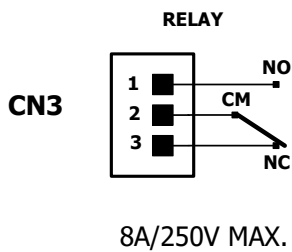

CAUTION:

Read the recommendations and related data on pages 8 and 9.

IMPORTANT:

To ensure electrical safety in accordance with EN 61010-1, an external 8A / 250V fuse must be installed as a protection measure.

Analog output connection (4-20mA)

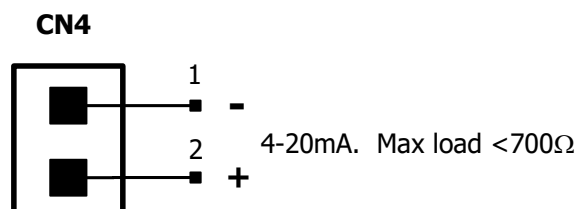

INPUT CONFIGURATION

Configuration menu

When connecting instrument to Power supply, display test begins automatically to check the good function of LED's and digits, once this test is finished, display shows internal software version and then the unit goes to **RUN** mode.

Configuration software has a hierarchical structure composed of a number of menus and submenus. By pressing **ENTER** key, display shows "Pro", a new pressing brings access to main menu where appear configuration menus, that is, input configuration (**InP**), display configuration (**dSP**), setpoints configuration (**SEtP**) and analog output configuration (**AnA**).

If configuration is totally locked-out, when pressing **ENTER** key to get into main menu, display shows "dAtA" instead of "Pro". This indicates that it is only possible to see programmed information and that it is not allowed to modify any parameter from the entire configuration. In this visualization mode, the instrument automatically switches back to **RUN** mode after 15 seconds since last key press.

The instrument provides 3 keys for progressing through the menus and submenus and for data introducing/modifying:

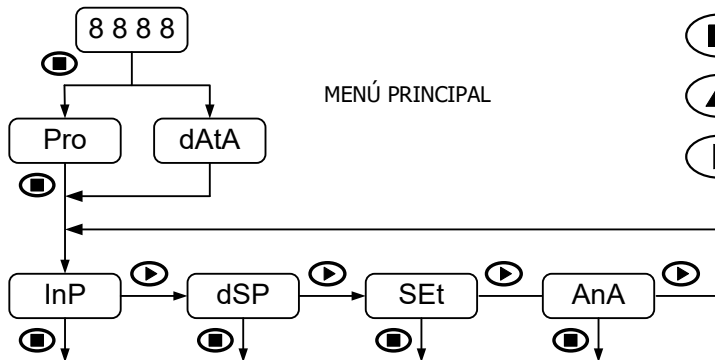

- ENTER**: Vertical displacement / Validates data.
- UP**: Increases active digit value.
- SHIFT/DOWN**: Horizontal displacement / Changes active digit / Decrements the display value of the setpoint generator in 'diMM' mode.

Once inside each menu, all configuration parameters are sequentially shown and they can then be introduced or edited by pressing **ENTER** key. Numeric values must be entered digit by digit, first selecting digit and then changing its value. When the display reach desired value, a new **ENTER** key pressing validates data and routine goes forward to next configuration step.

Data entered or changes made during configuration are stored in device memory only when programming routine belonging to the respective submenu is completed, not before. On last routine step and after having pressed **ENTER** key, display indicates "**StorE**" and the unit goes back again to **RUN** mode.

Input configuration

The first menu corresponds to input configuration. This menu, in turn, consists of two submenus: process (**ProC**), temperature (**tEMP**).

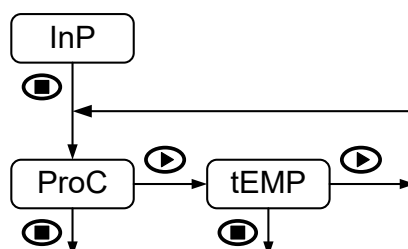

Process

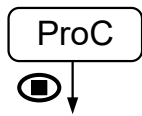

The parameters to be configured in input process submenu are:

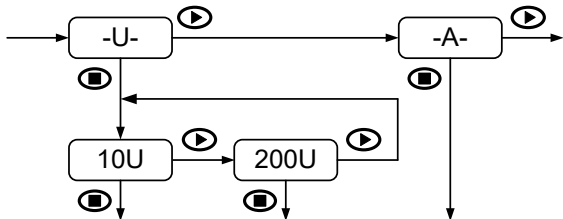

INPUT TYPE:

V DC: $\pm 10V$ or $\pm 200V$ (-tachometric dynamo-)

A DC: $\pm 20mA$ (single range, direct validation)

Temperature

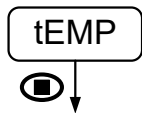

The parameters to be configured in input temperature submenu are:

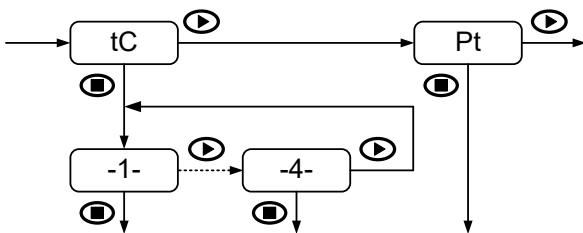

SENSOR TYPE:

tC: Termocouple **J(1)**, **K(2)**, **T(3)** or **N(4)**
Pt: Pt100 sensor (direct validation)

RESOLUTION TYPE:

1°C: Celsius degrees

0.1°C: Tenths of degree Celsius

1°F: Fahrenheit degrees

0.1°F: Tenths of degree Fahrenheit

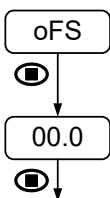
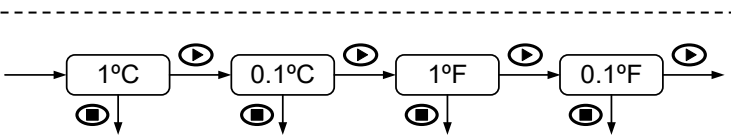

DISPLAY OFFSET :

Configurable value:

-9.9 to **+9.9** display counts if a tenths of degree resolution is selected

-99 to **+99** display counts if a degree resolution is selected

Usually it will not be necessary to introduce any offset value, except in cases where a known difference between temperature captured by the sensor and real temperature should be compensated.

DISPLAY CONFIGURATION

Display Programming

The second menu corresponds to display configuration. This menu, in turn, consists of some submenus according to previously programmed input type: through frontal keys configuration (**SCAL**), through real input signal (**tEAC**) (**tEAC**), and reading stabilization filter (**FiLt**).

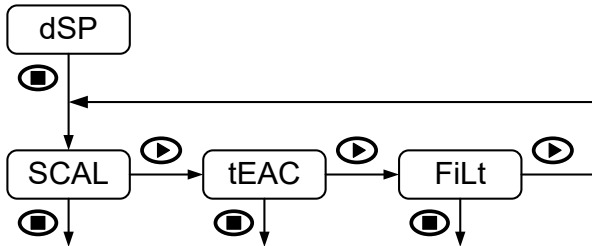

THROUGH FRONTAL KEYS CONFIGURATION "SCAL"

Input and display values are configured **manually through the three keys** of the instrument. This method is suitable when signal values supplied by the transducer at each extreme point of the process are known.

REAL INPUT SIGNAL CONFIGURATION "tEAC"

Input values are **directly introduced from CN2 input connector just at the moment of signal capturing at each point of the process**. Display values are configured manually through the three keys, as in the previous case. This method is suitable when signal values at each point are unknown but, it is possible to lead process to the conditions defined by these extreme points.

WEIGHTED AVERAGE FILTER "FiLt"

Sets low-pass filter cutoff frequency (Fc) which allows the instrument to smooth out undesirable display reading fluctuations.

Display scaling

Display scaling is necessary when adapting display reading to a particular engineering unit. Display range can be configured between **-9999** and **9999**.

Display scaling is a linear process that consists in introducing two input values, referred as **Input 1** and **Input 2**, and their respective display values, referred as **Display 1** and **Display 2**. On the basis of this proportional relationship internal software calculates display value that would correspond to a given input value. Decimal point position would complete required engineering units indication.

It is possible to scale display in an increasing or decreasing proportional mode depending on whether if second display value (**DISP.2**) is higher or lower than the first (**DISP.1**). In an increasing mode, display value increases proportionally to the input value whereas in a decreasing mode, display value decreases. The left figure below shows both scaling modes.

Increasing proportional mode

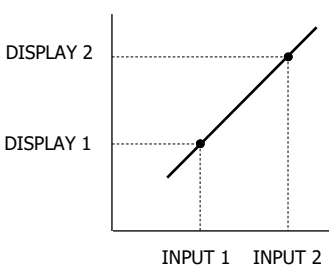

Decreasing proportional mode

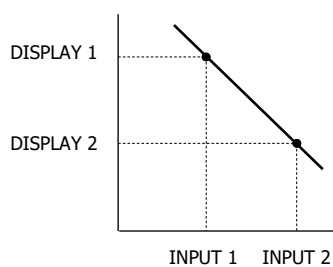

IMPORTANT IN "tEAC" MODE:

To ensure the best accuracy, both points 1 and 2 should represent extreme process limits.

The right figure shows an example for a 10 bar pressure sensor with a 4-20mA output signal. Decimal point is situated between second and third digit of the display.

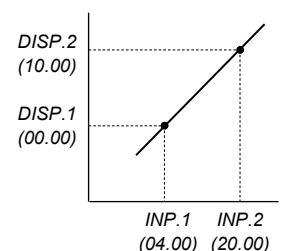

Process input

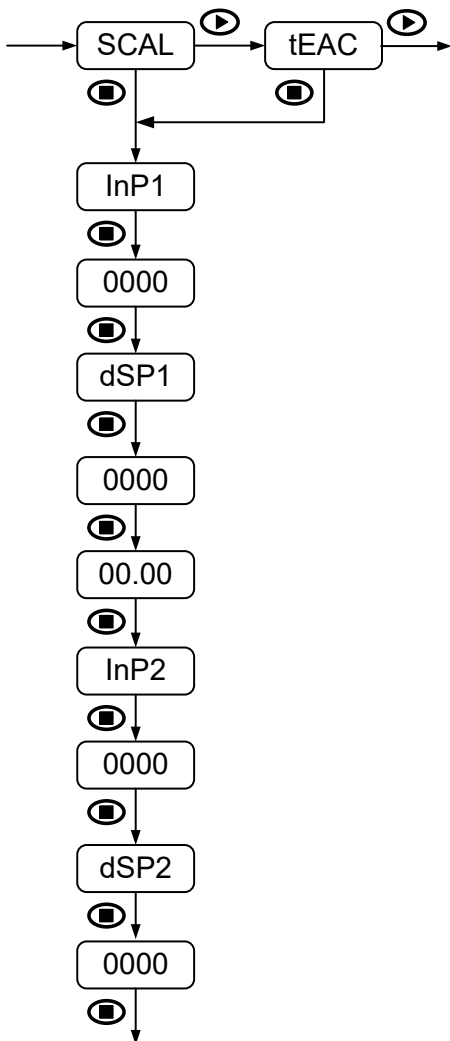

When programmed input type is process, for both display scaling "SCAL" and "tEAC" methods, parameters to be sequentially introduced are identical.

It only must be considered that in "SCAL" method, all values must be manually introduced through the three frontal keys whereas in "tEAC" method, input signal value must be present at the connector at each point that is intended to be configured.

FIRST POINT INPUT AND DISPLAY VALUE:

- InP1:** Input value indication.
- 0000:** Value entering in counts within display range.
- dSP1:** Display value indication.
- 0000:** Value entering in counts within display range.

DECIMAL POINT:

- 00.00:** Setting of decimal point position.
(Decimal point can be located in any position, and will be the same for Display 1 and Display 2. This position remains fixed for all configuration steps and also for **RUN** mode).

SECOND POINT INPUT AND DISPLAY VALUE:

- InP2:** Input value indication.
- 0000:** Value entering in counts within display range.
- dSP2:** Display value indication.
- 0000:** Value entering in counts within display range.

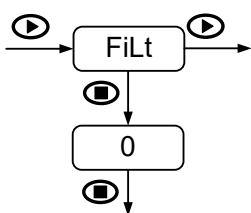

WEIGHTED AVERAGE FILTER:

FiLt: 0 to 9 configurable.



Value	Fc (Hz)	Value	Fc (Hz)
0	--	5	2.2
1	7.3	6	1.6
2	5.1	7	1.1
3	3.8	8	0.5
4	2.9	9	0.2

Temperature input

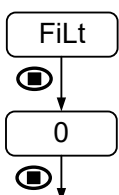

When programmed input type is temperature, for thermocouple and Pt100 sensor, the only parameter to configure is the filter and its configuration is done in the same way as described for process input.

Display scaling is not available for this input type, the unit then will assume a fixed calibrated range depending on sensor type and previously configured units resolution.

SETPOINT CONFIGURATION

Setpoint configuration menu

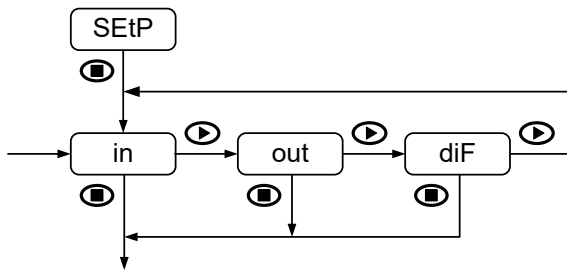

The third menu corresponds to the relay output. For more details on the operating modes, consult the section corresponding to this output later in this manual.

The parameters to configure are the following:

ACTIVATION MODE:

If the analog setpoint generator is enabled (see the configuration section of the analog output below), the alarm relay can be configured to activate according to:

- in:** A value of the input signal.
- out:** A value of the analog output.
- diF:** The absolute value of the difference in engineering units between input and output.

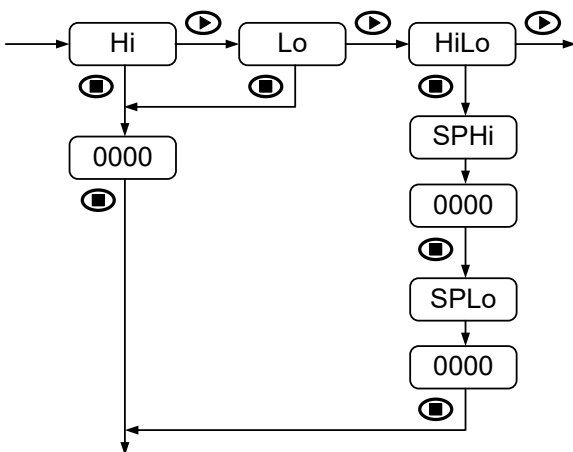

MODE OF ACTION:

- Hi:** Activation of the relay by high level.
- Lo:** Activation of the relay by low level.
- HiLo:** Activation of the relay within the window defined by the high ('SPHi') and low ('SPLo') levels.

For both the 'Hi' mode and 'Lo' mode, the setpoint value must be entered in points by 4 digits within the display range. For the 'HiLo' mode, the high level setpoint and the low level setpoint must be entered.

NOTE: It is not possible to change the position of the decimal point, this position is determined by the one that has been configured in the 'dSP' display menu.

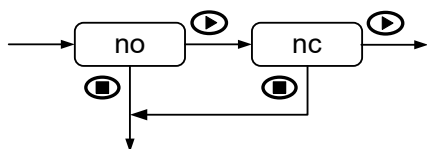

STATE OF RELAY IN REST:

- no:** Normally open contact.
- nc:** Contact normally closed.

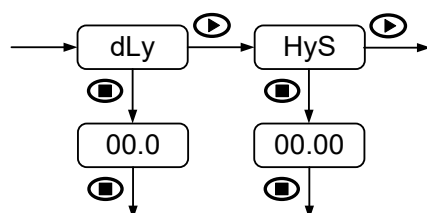

TIMING AND HYSTERESIS:

- dLy:** Programmable delay from 0 to 99.9s.
- HyS:** Hysteresis in points throughout the display range

ANALOG OUTPUT CONFIGURATION

Analog output configuration menu

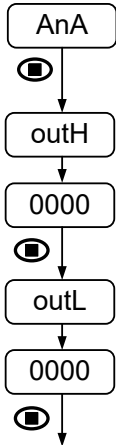

The fourth menu corresponds to the analog output. For more details on the operating modes, consult the section corresponding to this output later in this manual. The parameters to configure are the following:

RANGE OF ACTION:

Enter the two display values by 4 digits that will define the variation of the 4-20mA output signal.

Upper limit:

outH: Higher output value indication.

0000: Enter the value in display points within the available range. It will match an output signal of 20mA.

Lower limit:

outL: Lower value indication.

0000: Enter the value in display points within the available range. It will match an output signal of 4mA.

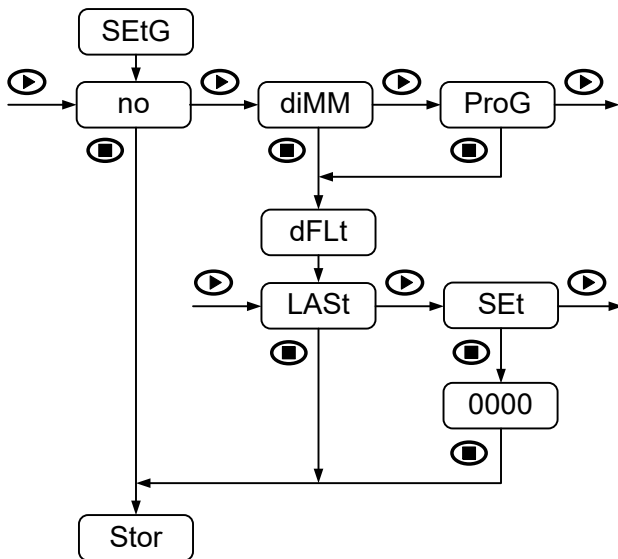

GENERATOR OF ANALOG SETPOINT:

SEtG: Setpoint generator indication.

no: Disable the setpoint generator.

Adjustment mode:

diMM: Enables the setpoint generator in regulator mode or 'Dimmer'.

ProG: Enables the set point generator in Programmed mode.

Initial value by default:

dFLt: Default value indication.

LASt: The initial default value will be the last one provided in 'Dimmer' mode or the last one entered in programmed mode.

SEt: Value setting indication.

0000: Enter the four digits of the default initial value.

NOTE: It is not possible to change the position of the decimal point, this position is determined by the one that has been configured in the 'dSP' display menú.

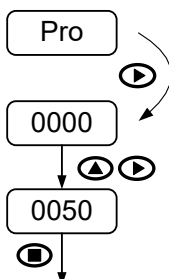

To adjust the value of the setpoint generator in programmed mode 'ProG', from the 'run' mode press the **ENTER** key and while the indication "Pro" is shown, press the **SHIFT** / **DOWN** key.

Enter the desired value digit by digit using the keyboard. Press the **ENTER** key to validate the data.

AVAILABLE KEYBOARD FUNCTIONS

In addition to already known functions used to browse through the configuration menus and submenus, introduce and/or modify existing values and parameters, the instrument provides some more added functions.

MAX/MIN and RESET functions

This device detects and stores in memory maximum and minimum values reached by the input signal. These values are kept in memory although power supply is disconnected. When pressing repeatedly **SHIFT** key, **MAX/MIN** function shows saved maximum and minimum values in display since last **RESET** function activation.

In order to differentiate this values indication from a mode **RUN** indication, decimal point blinks during the time these values are shown. The unit automatically switches back to **RUN** mode after 15 seconds have elapsed since the last key press.

First **SHIFT** key pressing shows "**MAH**" in display followed by the maximum value, a second pressing now shows "**Min**" followed by the minimum value and finally, a third pressing shows "**run**" to back again in an instant to **RUN** mode.

RESET function activates when visualizing maximum or minimum values **SHIFT** key is pressed for at least 3 seconds. If maximum is the displayed value, current input signal value will replace the previous maximum saved value. In the same way, current input signal will replace saved minimum value while is the minimum the displayed value.

Direct access to setpoints value

It is possible to directly access the configuration of the setpoint value, without having to go through the main configuration menu for the action modes 'Hi' and 'Lo', or, to the high and low level setpoint values, if the 'HiLo' operating mode is selected.

To access this submenu, from **RUN** mode and after **ENTER** key is pressed, simply press **UP** key while "**Pro**" is displayed.

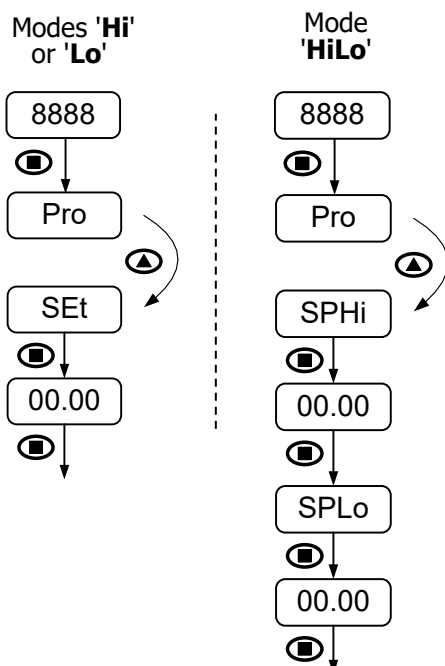

SETPOINT VALUE FOR 'Hi' or 'Lo' MODES:

- SEt:** Setpoint value indication.
- 00.00:** Value entering in counts within available model display range.

HIGH AND LOW SETPOINT VALUE FOR 'HiLo' MODE:

- SPHi:** Value indication for the high level Setpoint.
- 00.00:** Value entering in counts within available model display range.
- SPLo:** Value indication for the low level Setpoint.
- 00.00:** Value entering in counts within available model display range.

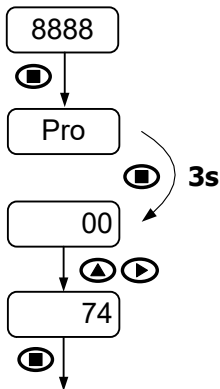
Return to default configuration

To access this menu from **RUN** mode, press **ENTER** key and while display shows "**Pro**" press again **ENTER** for at least 3 seconds.

Display shows now "**00**" and '**74**' code must be introduced through **SHIFT** and **UP** keys.

Finally press **ENTER** to validate configuration and back to **RUN** mode.

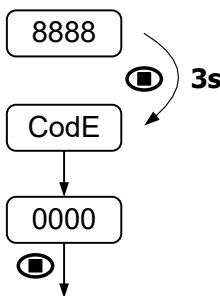
Access to lock-out configuration menu

To access this menu from **RUN** mode, press **ENTER** key for at least 3 seconds.

Display shows now "**CodE**" and then "**0000**". Desired security code must be introduced through **SHIFT** and **UP** keys (by default this code is **0000**).

Finally press **ENTER** to begin with lock-out level configuration. If entered security code is wrong, the instrument will go back to **RUN** mode.

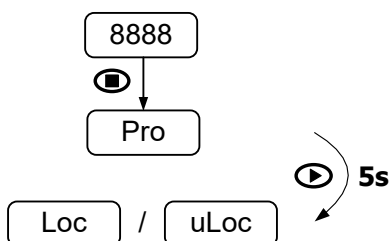
Lock-out the analog output setting

To enable / disable the adjustment of the analog output when the setpoint generator is activated, press the '**ENTER**' key and while the indication "**Pro**" is displayed, press the '**SHIFT**' / '**DOWN**' key for at least 5 seconds.

Then the indication "**Loc**" or "**uLoc**" is displayed depending on the last access to this function.

After a short period of time, the instrument automatically returns to **RUN** mode.

CONFIGURATION LOCK-OUT

Lock-out menu

In order to prevent accidental or undesirable modifications of instrument parameters, a selective or total configuration lock-out is available. By default the unit is delivered unlocked, giving access to all programming levels. Once in this menu, the first option will be to choose between lock-out level setting ("LiSt") or security access code changing ("CHAn") or display the software version (VEr).

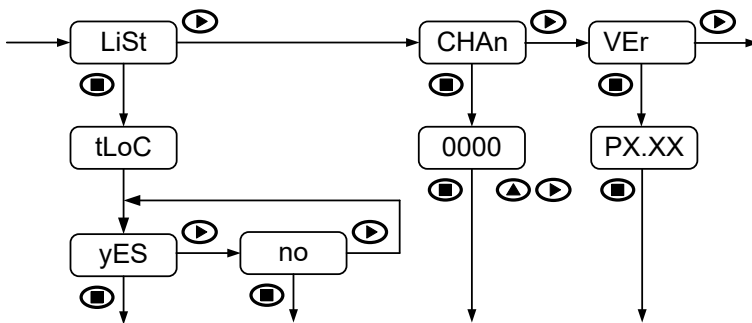

When choosing "LiSt" the indication "tLoC" appears for a moment. Choosing "yES" again activates the total block and jumps directly to the **MAX / MIN** function lock setting, then returns to **RUN** mode. When the device is **completely blocked**, all the configuration can be accessed, **although it will not be possible to enter and / or modify data**. When you enter the main menu, "dAtA" will appear instead of "Pro".

If on the other hand "no" is chosen, the routine continues to configure the partial access level. In the future, it will only be possible to access the non-blocked configuration. When entering the main menu, "Pro" continues to appear.

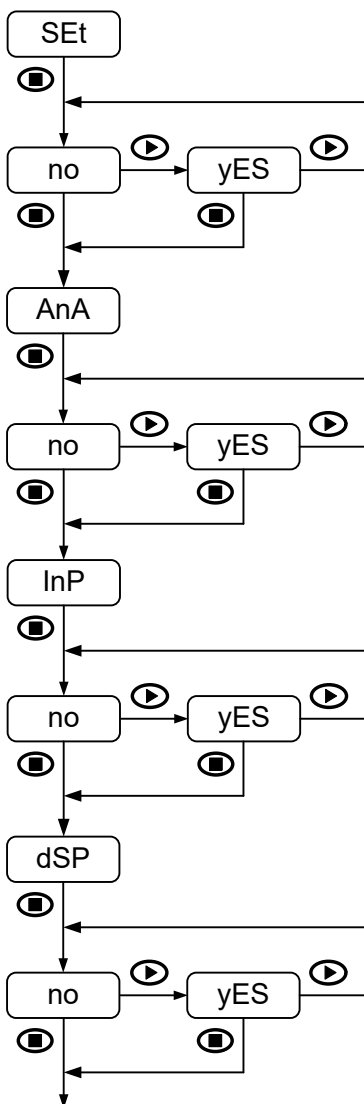

The following configuration access can be locked-out:

- Setpoint configuration (**SEt**)
- Analog output configuration (**AnA**)
- Input configuration (**InP**)
- Display configuration (**dSP**)
- **SHIFT** key configuration for MAX/MIN function (**MAH**)

In each case lock-out is activated by selecting "yES" option and deactivated by selecting "no".

When choosing "CHAn" the indication "0000" corresponding to the current access code appears and it can be changed digit by digit using the keyboard, to validate the new code and return to RUN mode, press the 'ENTER' key. If the access code is changed, it is recommended to write the new code in a safe place.

When choosing "VEr", the firmware version installed on the device appears next. Press the 'ENTER' key again to return to **RUN** mode .

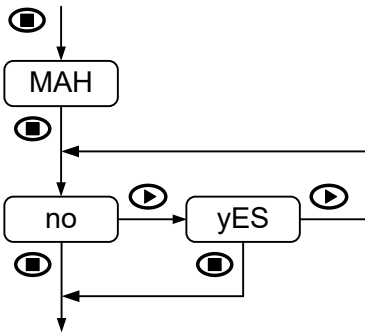

When the lock is activated (by selecting "yES") it is not possible to display the maximum and minimum values by means of the 'SHIFT' key, although internally the instrument continues detecting and memorizing the extreme values reached by the input signal.

If the setpoint generator 'SEtG' is activated, this last step of the menu is not visible, although as in the previous case, the instrument continues detecting and memorizing the extreme values reached by the input signal.

Once all the configuration of the instrument has been completed, if there are parameters that are going to be readjusted frequently, it is recommended to perform a partial lock-out. If no changes are foreseen, it is recommended to carry out a total lock-out.

RELAY OUTPUT

Description

The relay output allows the IDEAL-P unit to carry out control operations and treatment of limit values by means of an ON / OFF output that is already integrated in the indicator itself.

In general, the alarm is activated when the display value reaches the Setpoint value programmed by the user (the indication on the display flashes). However, if the setpoint generator is activated, it can also be activated with a value of the output signal or with the absolute value of the difference between the input signal and the output signal. For the configuration of the same it will be necessary to determine also the mode of action.

Description of the operating modes

HI, LO or HILO operating mode

In **HI** mode the output is activated when the value of the compared quantity, depending on the configuration, exceeds the Setpoint value.

In **LO** mode, the output is activated when the value of this quantity falls below the entered Setpoint value.

In **HILO** mode, the output is activated when the value of this quantity is outside the range defined by the upper and lower limits established by the Setpoint values "**SPHi**" and "**SPLo**" entered respectively.

Timing

On the alarm a configurable timed delay can be entered in seconds from 0 to 99.9s.

The activation of the delay starts when the display value passes through the set point '**SET**', either in ascending or descending direction, causing the delay 'dly' in the activation of the output as can be seen in the two examples of the figure.

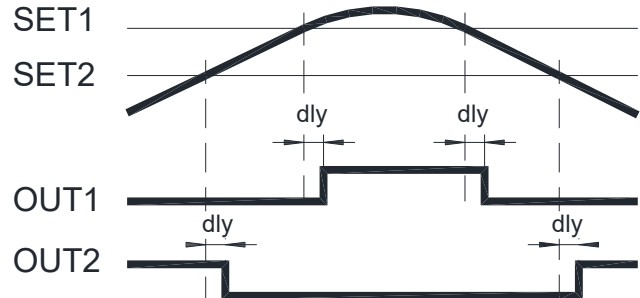

Time delay in **HI** mode (SET1-OUT1) and in **LO** mode (SET2-OUT2).

Asymmetric hysteresis

On the alarm, a configurable delay can be entered in display points from 0 to 9999. The position of the decimal point is imposed by the programming carried out previously.

The activation of the delay is carried out on the deactivation flank or on the activation flank of the output relay, depending on whether it is configured in '**Hi**' mode or '**Lo**' mode respectively, causing the delay 'hys 1' and 'hys 2', as can be seen in the two examples of the figure.

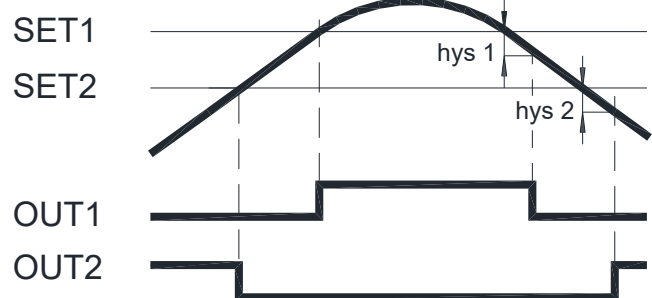

Hysteresis delay in **HI** mode (SET1-OUT1-hys 1) and in **LO** mode (SET2-OUT2-hys 2).

Note that the activation of the output in '**Hi**' mode and the deactivation of the output in '**Lo**' mode are not altered by the hysteresis and are carried out just at the moment in which, in each case, the setpoint is reached '**SET1**' or '**SET2**'.

ANALOG OUTPUT

Description

The built-in output allows the IDEAL-P unit to provide a range of analog signal of 4-20mA linearly proportional to the variation of the display defined by the user through the display configuration menu. It is an isolated output with respect to the input signal and the power supply.

Description of the operating modes

In general, the delivered signal can be used to control variables and act at all times proportional to the magnitude of the effect under control, transmit the display information to graphic recorders, controllers, remote displays or other repeater instruments.

The output signal can be increasing or decreasing depending on the display value assigned to the parameters '**OutH**' and '**OutL**' present in the configuration menu of the output. If '**OutH**' > '**OutL**', the output signal increases when the display does so whereas for '**OutH**' < '**OutL**', the signal decreases when the display increases.

On the other hand, if the setpoint generator ('**SetG**') is activated, it will be possible to generate said signal in regulator mode / 'dimmer' ('**dIMM**') or programmed ('**ProG**') as configured in the corresponding menu.

Setpoint generator

When the analog setpoint generator is enabled, the display shows the analog output scaled in the engineering unit. The 4-20mA output can be modified by changing the value on the display through the front keypad. In these conditions the signal from a sensor is not necessary since the output is independent of said input signal.

In regulator mode or 'Dimmer' ('**dIMM**') the output is adjusted using the '**UP**' and '**DOWN**' keys. In programmed mode ('**ProG**'), the output is set digit by digit starting from the **RUN** mode by pressing '**ENTER**' and then '**DOWN**'. Once the value has been entered, a new press of the '**ENTER**' key validates the data by returning to the **RUN** mode. The limits of adjustment in both cases will be those defined by the values entered in the parameters '**OutH**' and '**OutL**', regulation outside of them will not be possible.

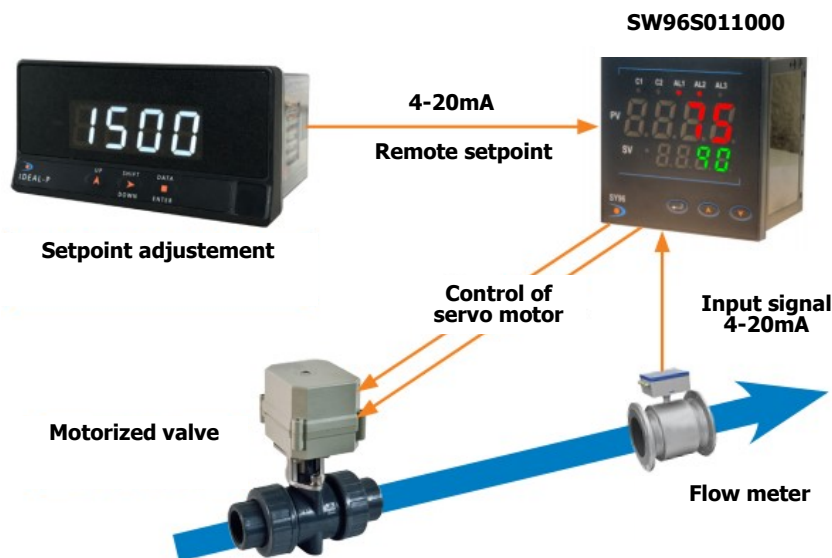

Application example. Sending remote setpoint to a device that regulates a motorized valve and controls its action by reading a flow meter.

SPECIFICATIONS
Technical specifications
SPECIAL FUNCTIONS

- Return to factory settings.
- Lock-out software programming
- Setpoint generator

ACCURACY

- Temperature coefficient..... 100 ppm/°C
- Warm up time..... 15 minutes
- Specifications range 23°C±5°C

POWER SUPPLY and FUSES (DIN 41661) (not included)

- IDEAL-P:**
- 20-265 V AC 50/60 Hz and 20-265 V DC F 3A/ 250V
- Power consumption..... 4.5W
- Excitation 24V±3V@30mA

CONVERSION

- Technique Sigma-Delta
- Resolution 16 bits
- Conversion rate..... 20/s

DISPLAY

- Range -9999 ÷ 9999, 14mm LED white
- Decimal point programmable
- Display refresh rate 50ms
- Display/Input overrange indication "-Oue", "Oue"
- Sensor failure indication "Oue"

ENVIRONMENTAL CONDITIONS

- Operating temperature -10°C à +60°C
- Storage temperature -25°C à +85°C
- Relative humidity (non-condensing) <95% @ 40°C
- Maximum altitude 2000m
- Frontal protection degree IP65

INPUT SIGNAL

- Configuration Differential asymmetrical

PROCESS

- ±10V DC y ±200V DC input impedance 2MΩ
- ±20mA DC input impedance..... <20.5Ω
- Maximum input signal (range ±10V) ±11V
- Maximum input signal (range ±200V) ±205V
- Maximum input signal (range ±20mA) ±22mA
- Maximum continuous overload (±10V / ±200V) ±300V
- Maximum continuous overload (±20mA) ±50mA
- EMI Max. Influence (±10V) ±7mV
- EMI Max. Influence (±200V) ±60mV
- EMI Max. Influence (±20mA) ±6mA

RANGE	RESOLUTION	ACCURACY
±10V	1mV	±(0.1%R + 6mV)
±200V	20mV	±(0.1%R + 0.1V)
±20mA	2µA	±(0.1%R + 15µA)

TEMPERATURE

- Pt100 measurement current 1mA
- Pt100 maximum wire resistance..... 40Ω (balanced)
- Pt100 linearization IEC 60751
- Pt100 α coefficient 0.00385
- Thermocouple cold junction compensation range ... -10°C÷60°C
- EMI max. influence(Pt100) ±1.3°C
- EMI max. Influence (Thermocouple) ±6°C

Pt100 (3 wires)		
RANGE	RESOLUTION	ACCURACY
-200.0°C to +800.0°C	0.1°C	±(0.15%R + 0.5°C)
-200°C to +800°C	1°C	±(1%R + 0.5°C)*

*Only for temperatures t<-50°C/-58°F

THERMOCOUPLE J		
RANGE	RESOLUTION	ACCURACY
-150.0°C to +999.9°C	0.1°C	±(0.1%R + 0.6°C)
-150°C to +1100°C	1°C	

THERMOCOUPLE K		
RANGE	RESOLUTION	ACCURACY
-150.0°C to +999.9°C	0.1°C	±(0.1%R + 0.6°C)
-150°C to +1200°C	1°C	

THERMOCOUPLE T		
RANGE	RESOLUTION	ACCURACY
-150.0°C to +400.0°C	0.1°C	±(0.2%R + 0.8°C)
-150°C to +400°C	1°C	

THERMOCOUPLE N		
RANGE	RESOLUTION	ACCURACY
-150.0°C to +999.9°C	0.1°C	±(0.1%R + 0.6°C)
-150°C to +1300°C	1°C	

FILTER

Cutoff frequency (-3dB) 7.3Hz to 0.2Hz
 Slope -20dB/Dec.

DIMENSIONS

Dimensions 96 x 48 x 60mm
 Panel cutout 92 x 45mm
 Weight 150g
 Case materialUL 94 V-0 polycarbonate

ANALOG OUTPUT

Range 4-20mA
 Response time 50ms
 Temperature coefficient 0.5 μ A/ $^{\circ}$ C
 Maximum load < 700 Ω
 Resolution 13 BITS
 Accuracy $\pm(0.1\%FS + 40\mu A)$

RELAY OUTPUT

Maximum switching current (resistive load) 8A
 Maximum switching power 2000VA / 192W
 Maximum switching voltage 400VAC / 125VDC
 Contact rating 8A @ 250VAC / 24VDC
 Contact resistance $\leq 100m\Omega$ at 6V DC @ 1A
 Contact type SPDT
 Operate time $\leq 10ms$

NOTE:

In case that the outputs are used to drive inductive loads, it is recommended to add an RC network between the coil terminals (preferably) or between the relay contacts, to limit electromagnetic effects and to extend contacts life.

NOTES:
INSTRUMENT CONFIGURATION

Use the following template for the annotation of configured parameters in your instrument for later consulting or data recovery.

INPUT:

TYPE:

RANGE:

DISPLAY:

CONFIG. MODE:

 SCAL tEACH CAL

INPUT 1:

DISPLAY 1:

INPUT 2:

DISPLAY 2:

FILTER (0 ÷ 9):

RELAY OUTPUT:

SETP:

MODE:

 no nc

DLY:

HYS:

ANALOG OUTPUT:

OUTH:

OUTL:

MODE:

 SEtG dIMM ProG

DFLT:

SET:

LOCK-OUT:

ACCES CODE:



DISEÑOS Y TECNOLOGÍA, S.A.
Xarol, 6B P.I. Les Guixeres
08915 Badalona (Barcelona) - España.

Tel. +34 933 394 758
Fax +34 934 903 145
Email: dtl@ditel.es ; web: www.ditel.es